



THE WORLD LEADER IN
FUME EXTRACTION TECHNOLOGY

AD Base 1 Oracle

Advantage

The Advantage Base 1 Oracle has been designed so that a number of manufacturer's laser engravers can sit on top of the extractor, effectively doubling it up as a work station.

All the Base units in the range have the option of an onboard compressor for a compact installation. BOFA's 'Easi-Seal' filter location makes filter change easy, quick and safe.

The revolutionary Auto-Voltage Sensing Turbine automatically self adjusts to run on any voltage worldwide, whilst the Reverse Flow filter technology enhances filter performance and ensures longer filter life.

Automatic Flow Control allows the user to preset correct flow rates, giving lower noise levels and further protection of both the combined filter and the DeepPleat DUO pre filter.

STANDARD FEATURES:

- Auto sensing voltage (90-257v) for global use
- Automatic flow control
- DeepPleat DUO pre filter
- Advanced Carbon Filter technology
- HEPA and Gas combined filter
- Reverse flow
- 'Easi-Seal' filter location
- Small footprint
- Low noise levels

The laser companion Advantage extraction system for the laser engraving industries.



Featuring DeepPleat DUO filter technology



Featuring Advanced Carbon Filter technology

OPTIONAL FEATURES:

- VOC gas sensors (Volatile Organic Compound)
- Onboard compressor
- Remote stop / start interface
- Filter change / System fail signal



PART NUMBERS						
Model	Voltage	Part No.	24V Stop / Start	Filter change / System failure signal	VOC Monitoring	Compressor
AD Base 1 Oracle Powder Coated	90 - 257V	L5144	A2001	A2002	A2003	A2007
AD Base 1 Oracle with compressor Powder Coated	230V	L5142				
	115V	L5141				

REPLACEMENT FILTERS		
Model	DeepPleat DUO Pre Filter	Combined filter
AD Base 1 Oracle	A1030156	A1030155

TECHNICAL DATA	
	90-257V
Dimensions (HxWxD)	795 x 735 x 740mm (31.3 x 28.9 x 29.1")
Cabinet Construction	Powder coated mild steel
Airflow / Pressure	380m ³ /hr / 96mbar (223cfm / 96mbar)
Electrical Data	90 - 257v 1ph 50/60Hz Full load current: 12.5 amps / 1.1kw
Noise Level	< 63dBA*
Weight	86kg (189lbs)

* At typical operating speed.

DEEPPLEAT DUO PRE FILTER SPECIFICATIONS	
Surface Media Area	12m ² approx
Filter Media	Glass Fibre
Filter Media Construction	Maxi Pleat with webbing spacer
Filter Housing	Zintec mild steel
Filter Efficiency	F8 (95% @ 0.9 microns)

COMBINED FILTER SPECIFICATIONS	
HEPA Filter Media	Glass Fibre
HEPA Media Construction	Maxi Pleat Construction with Webbing Spacers
Filter Housing	Zintec Mild Steel
Treated Activated Carbon	15kgs
Filter Efficiency	99.997% @ 0.3 microns

AIRFLOW THROUGH FILTERS

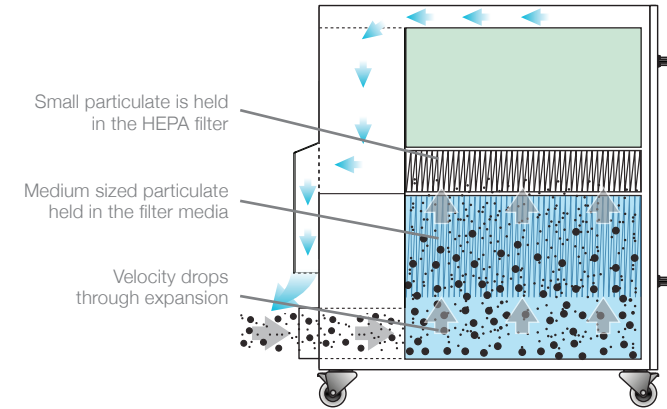
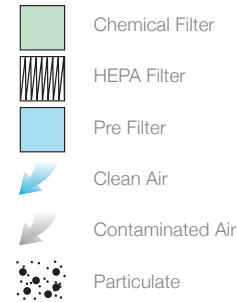

TECHNICAL SPECIFICATION

- | | |
|------------------------------------------------------------|--------------------------------|
| 1 Unit / Filter Condition Display - Automatic Flow Control | 5 Castors |
| 2 On / Off Switch | 6 Door Hinge |
| 3 Standby button | 7 Hose Inlet Connection - 75mm |
| 4 Power Cable Inlet | 8 Exhaust Outlet |
| | 9 Motor Cooling Inlet |

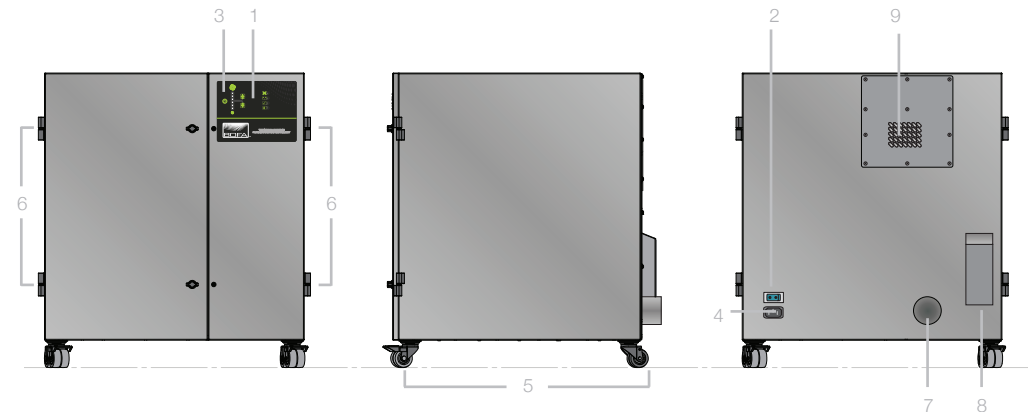

Other hose kits and filters are available. All of the above units are fitted with our standard filter combinations. For specific applications please call us for details. Replacement filters should always be ordered using the part number on the filters inside your extractor to ensure the correct filter is ordered. Datasheet correct at time of print.

Date:8/10/14 V:1.2



BOFA INTERNATIONAL LTD

Tel: +44 (0) 1202 699 444 Fax: +44 (0) 1202 699 446 Email: sales@bofa.co.uk Web: www.bofa.co.uk

BOFA AMERICAS, INC

Tel: (618) 205 5007 Fax: (866) 707 2632 Email: sales@bofaamericas.com Web: www.bofaamericas.com

